

# PRODRY | Dehumidifier



44



62



96

## FEATURES

- The Prodry dehumidifier has a solid metal body work.
- Stackable construction.
- Automatic stop when the water container is full.
- Equipped with an hour counter, hygostat and a defrosting system.

## ADVANTAGES

- A condensate pump is available as an accessory.
- The air filter can be easily cleaned and replaced.

## APPLICATIONS

- Dehumidifying after water damage because of leakage.
- Drying of areas in construction sites or renovation projects.
- Management of humidity level.

## WORKING PRINCIPLE

Areas are dehumidified according to the condensation principle.

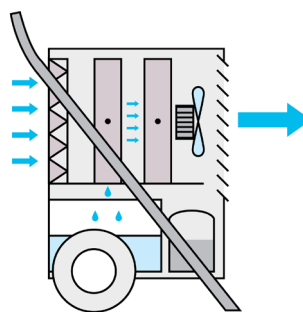

## TECHNICAL SPECIFICATIONS

PRODRY SERIES	44	62	96
Capacity Max. (l/24hr)	44	62	96
Capacity 20°C/60% RH (l/24hr)	14	19	30
Capacity 27°C/80% RH (l/24hr)	26	36	60
Capacity 30°C/80% RH (l/24hr)	36	52	80
Capacity 32°C/90% RH (l/24hr)	44	62	96
Airflow (m³/hr)	450	550	1.000
Tank capacity (l)	8	14	14
Working temperature °C	7 - 35	7 - 35	7 - 35
Power supply	230V/50Hz	230V/50Hz	230V/50Hz
Power consumption (kW)	0.8	0.92	1.48
Power consumption at start (A)	16	22	28
Refrigerant	R410A	R410A	R410A
Noise dB (3m)	46	52	52
Dimensions L*W*H (cm)	48*50*80	54*52*80	65*58*100
Weight (kg)	39kg	45kg	56kg
Item number	99.999.906	99.999.907	99.999.930